

# Industrial Laser Diode Modules



Designed and constructed to withstand harsh conditions and satisfy rigorous industrial applications, this range of robust industrial laser modules offers a very high level of performance and has been specifically designed to meet the needs of industrial OEM applications. A hard -coated anodised case and a scratch-resistant sapphire window are provided with a range of options for electrical connection including a screw-on connector or a 2.5mm DC jack. This rugged design can be combined with a user adjustable focus to allow integrators maximum flexibility while still ensuring a compact, robust and reliable product.

The industrial laser module is available in a variety of wavelengths from 635nm to 830nm and optical output powers from 0.9mW to 30mW, depending on the choice of optics.

Line generators are available with either a 45°, 60° or 90° full fan angle line and cross generating optics generate an accurate 70° full angle cross. The lens system produces a Gaussian intensity laser line which offers straight line precision without bowing. The beam is aligned to <math><0.25^\circ</math> of the mechanical axis of the laser.

The industrial range has been designed as a complete laser solution for heavy duty industrial alignment and positioning applications and also provides an ideal solution for use in guidance systems for robotic equipment.

ProPhotonix has more than fifteen years of experience in providing lasers for the most demanding requirements and can provide custom solutions for specific applications. For further information on how ProPhotonix can meet your solution requirements contact us.

## Key Features

- Elliptical beam, line & cross generating optics available
- Robust, reliable and compact design
- Excellent bore-sighting <math><0.25^\circ</math>
- Scratch-resistant sapphire window protects lens
- Available in wavelengths from 635nm to 830nm
- Output powers from 0.9mW to 30mW

## Key Applications

- Industrial Alignment
- Industrial Positioning
- Guidance systems

## Product Specifications

Specifications	
Power Stability	<5%
Pointing Stability	<0.2mrad/°C
Bore Sighting	<0.25°
Operating Voltage (DC)	5V DC Regulated +- 10%
Case	Electrically Isolated
Circuit Protection	Static, Surge and Reverse Polarity
Connector Types	IP68M 12x 1mm Male Connector 2.5mm DC Male Connector
Operating Temperature	-10 °C to +50 °C
Storage Temperature	-40 °C to +80 °C
Housing Material	Aluminum - Hard Anodised Black
Exit Aperture Protection	Glass Sapphire Window
Certifications	All Products are RoHS Compliant
Warranty	1 Year

## Line Generating Optics Specifications

Wavelength (nm)	Power (mW)	Max. Operating Current (mA)
635	5	50
	10	105
	15	105
	30	130
650	5	70
	30	85
670	5	45
780	5	90
830	20	100

Line Thickness - nominally 1mm @1m (Other options available on request)  
Intensity Profile : Gaussian

## Elliptical Beam - Fixed Focus

Wavelength (nm)	Power (mW)	Max. Operating Current (mA)
635	0.95	45
	4	50
	10	50
	15	105
	30	135
650	0.95	45
	4	45
	30	85
670	0.95	45
	4	45
780	0.95	55
	4	55
830	30	100
Beam Size @ Aperture		3.5mm X 1.5mm
1/2 Angle Beam Divergence		0.3 x 0.6mrad typ

## Fan Angles for Line Generating Optics

Fan Angles (°)
45°
60°
90°

## Cross Generating Optics Specifications

Wavelength (nm)	Power (mW)	Max. Operating Current (mA)
635	0.9	45
	4	50

## Fan Angles for Cross Generating Optics

Fan Angles (°)
70°

## Spot Modules

### DC Jack

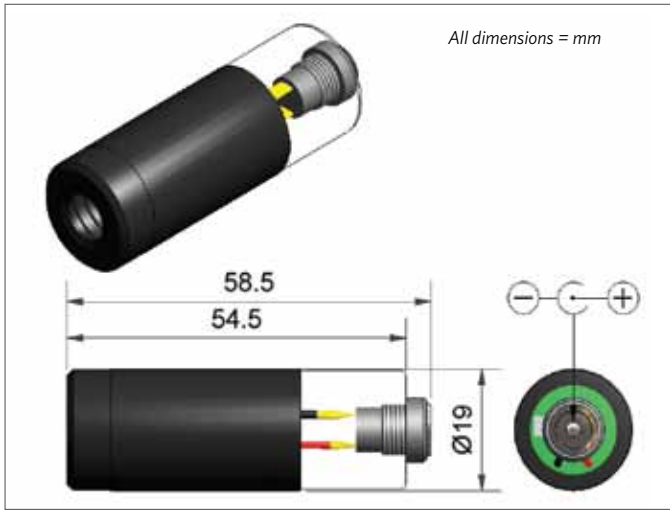

### Screw Connector

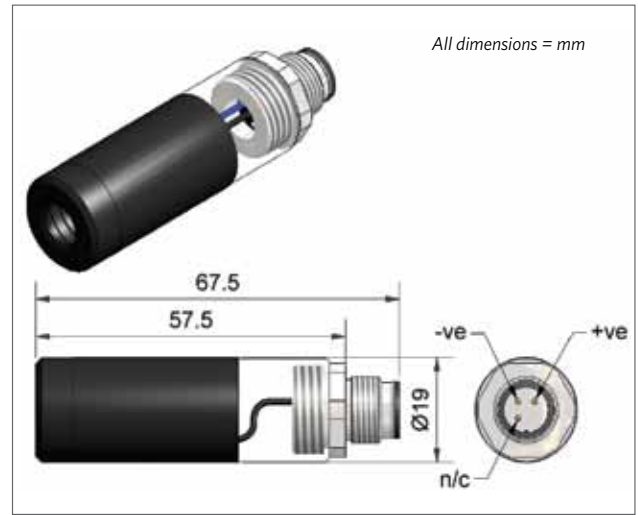

## Line and Cross Beam Modules

### DC Jack

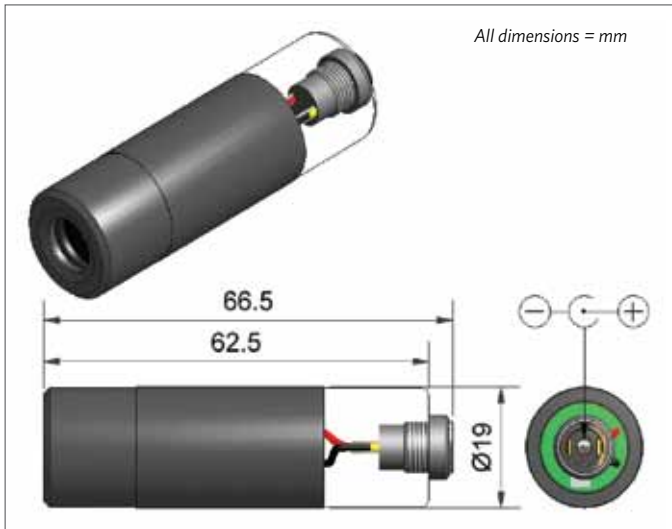

### Screw Connector

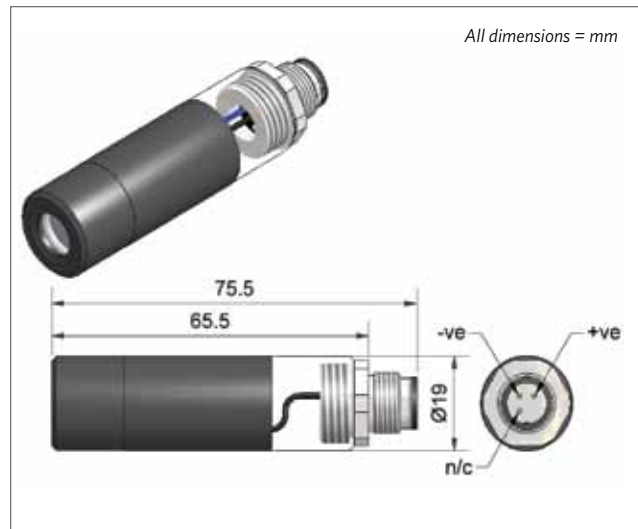

## Custom Solutions

ProPhotonix specializes in the provision of custom solutions and can provide other wavelengths, diode powers and optics if required.

## Part Numbers

To order your Industrial Laser Diode Module use the Product Code IND - Select Focus (F - Fixed) - Select Wavelength (XXX) Select Power (XXX)- Select Beam Shape (E - Elliptical/L - Line/C - Cross) - Select Fan Angle (XX) (*Fan Angle for Line and Cross Optics ; XX for Spot*) - Select Connector (DC - Jack/SC - Screw on Connector).

e.g IND - F - 635 - 005 - L - 45 - DC

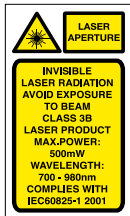
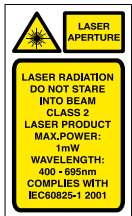
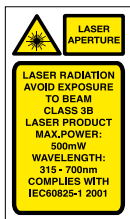
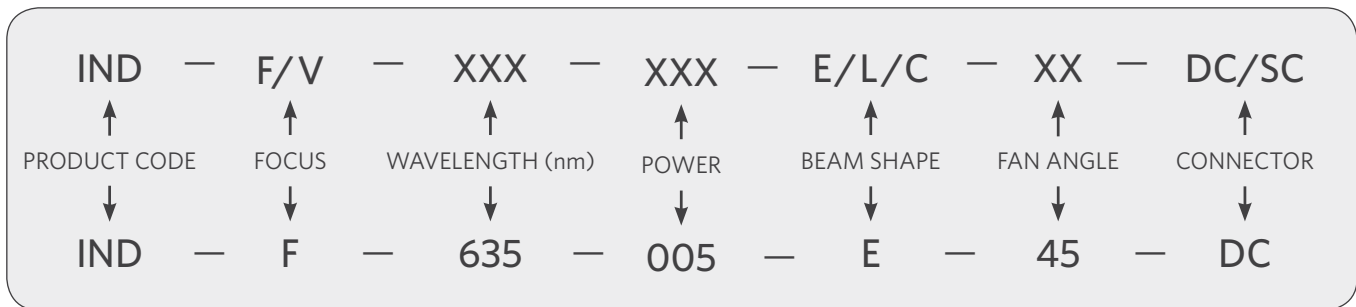

### Heat Sinking

If the case temperature of the laser diode exceeds its maximum specification, premature or catastrophic failure may occur. To ensure the maximum life of the laser diode, it is recommended that an additional electrically insulated heatsink, of at least 35 sq.cm. be used. Thermal transfer cream can be used to improve contact and heat dissipation. Do not restrict air circulation around the device.

### Power Connections Industrial

The laser diode modules require a regulated input voltage of 5V DC.

### Laser Safety

The light emitted from these devices has been set in accordance with IEC60825. However, staring into the beam, whether directly or indirectly, must be avoided. IEC60825 classifies laser products into three categories depending on light emitted, wavelength and eye safety.

**CLASS II:** "Caution", visible laser light less than 1.0mW. Considered eye safe, normal exposure to this type of beam will not cause permanent damage to the retina.

**CLASS IIIR:** "Danger", visible laser light between 1.0mW and 5.0mW. Considered eye safe with caution. Focusing of this light into the eye could cause some damage.

**CLASS IIIB:** "Danger", infrared (IIR), and high power visible laser considered dangerous to the retina if exposed.

*NB: It is important to note that while complying with the above classifications, unless otherwise stated, our laser diode products are not certified and are designed solely for use in OEM products. The way in which the device is used in the final product may alter its original design classification, and it is the responsibility of the OEM to ensure compliance with the relevant standards.*

20011

## Solutions for LEDs

ProPhotonix  
3020 Euro Business Park, Little Island  
Cork, Ireland  
ledsales@prophotonix.com  
Tel: +353-21-5001300

## Solutions for Lasers

ProPhotonix  
Sparrow Lane, Hatfield Broad Oak  
Hertfordshire, CM22 7BA, UK  
lasersales@prophotonix.com  
Tel: +44-1279-717170

## Corporate

ProPhotonix  
32 Hampshire Road  
Salem, NH 03079  
sales@prophotonix.com  
Tel: +1 603-893-8778