

COBRA™ Flex

Linescan Illuminator



All the functionality with added flexibility

The new COBRA™ Flex from ProPhotonix has been designed for high-speed linescan and web inspection where installation space is restricted. This innovative new product offers the extreme brightness and high uniformity of our COBRA Slim product in a more flexible package. The control electronics are housed separately allowing for a more compact light module. A number of mounting options are available to allow for maximum flexibility and the modular nature of the product means that it is available in any length up to 5 metres.

UV, Visible & IR wavelengths are available along with a wide range of optical options to ensure the optimum illumination for your application. Additional options include strobing function and onboard Ethernet control.

COBRA Flex is also available in a COBRA Max Configuration which can deliver up to twice the intensity of the standard COBRA Flex. For more information see COBRA Max datasheet.



Key Features

- Compact design with flexible mounting options
- Extreme brightness & high uniformity
- Field adjustable focusing distance & diffusers
- Wavelengths from UV to visible and IR

Options Available

- Strobing function (Potential for 5 times brighter)
- Onboard Ethernet control

Key Applications

Web & Linescan inspection of:

- Foil
- Plastic Film
- PCBs
- Glass
- Paper
- Currency
- Semiconductor
- Flat Panel Displays

Spectral Characteristics

Colour		UV ₃₆₅	UV ₃₉₅	Blue ₄₇₀	RED ₆₃₀	IR ₈₇₀	IR ₁₀₅₀	WHITE
Peak Wavelength ⁽¹⁾	nm	365±5	395±5	470±10	625±5	870±10	1050±20	550±10
Spectral Width FWHM	nm	12	14	27	15	47	75	115
Colour Temperature	K	n/a	n/a	n/a	n/a	n/a	n/a	5150-5350

(1) Nominal wavelengths and tolerance include thermal shifting

Maximum Irradiance & Illuminance (Measured in S9 For 100 mm Units)

		UV ₃₆₅	UV ₃₉₅	Blue ₄₇₀	RED ₆₃₀	IR ₈₇₀	IR ₁₀₅₀	WHITE
Convection Cooled								
Irradiance	Wm ⁻²	290	696	820	1164	1024	923	1046
Illuminance	kLux	n/a	n/a	53	273	n/a	n/a	373
Fan Cooled								
Irradiance ⁽²⁾	Wm ⁻²	725	2088	2305	2437	2048	2025	2382
Illuminance	kLux	n/a	n/a	149	572	n/a	n/a	851

(2) Values for active cooling presented here correlate to the integrals of the graphs shown on page 3.

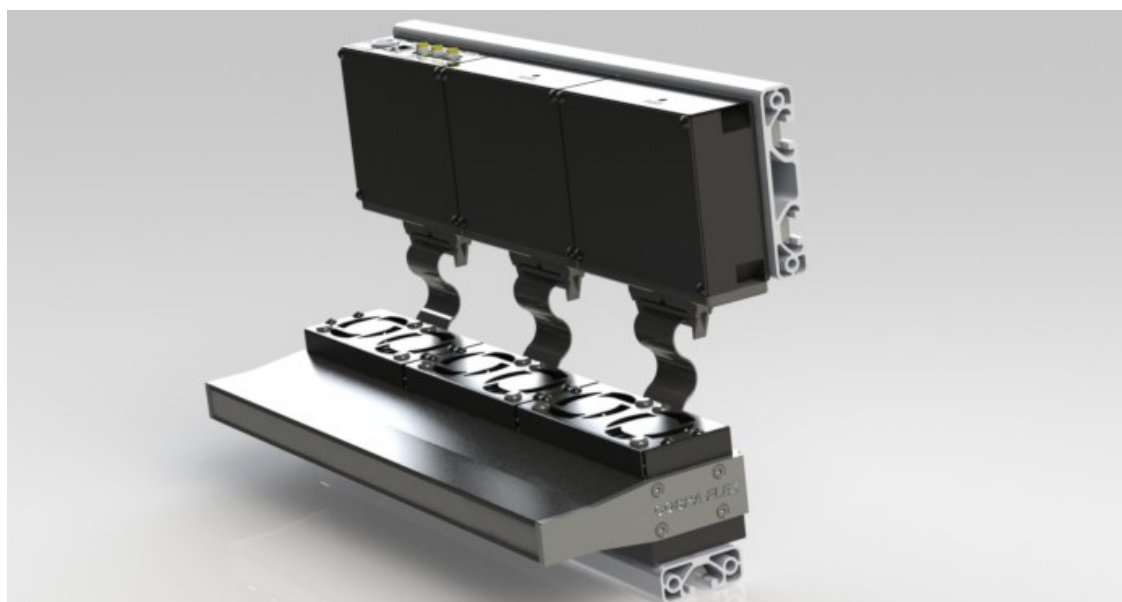

Focus & Illumination Field - RED COBRA Flex

Lens Position ⁽³⁾	Working Distance (WD) Range For Illuminance ⁽⁴⁾ (mm)		Working Distance (WD) At Peak Intensity(mm)		Line Width (FWHM) For WD Range (mm)		Focal Distance (mm)	Line Width ⁽⁵⁾ mm (FWHM) At Focal Distance
	100mm	300mm	100mm	300mm	100mm	300mm		
S1	10-66	10-125	divergent	divergent	14.2-18.7	13.2-22.8	divergent	divergent
S2	10-77	10-140	divergent	divergent	13.8-16.3	12.9-19.1	divergent	divergent
S3	10-95	10-181	divergent	divergent	12.0-13.2	11.8-13.7	divergent	divergent
S4	10-122	10-265	collimated	collimated	8.8-11.8	7.7-11.7	collimated	collimated
S5	10-47	10-120	10	29	8.0-10.9	4.9-11	149	4.7
S6	10-108	27-122	81	89	2.9-10.1	3.2-8.1	131	3.1
S7	44-87	50-94	68	74	4.5-2.2	2.5-4.4	95	2.5
S8	40-75	43-76	59	61	1.9-4.0	1.9-3.8	77	1.9
S9	33-60	41-65	47	54	1.5-3.9	1.6-3	68	1.6
D1	10-52	10-58	divergent	divergent	9.9-13.8	12.5-22.8	divergent	divergent

(3) Positions S1, S2 and S3 are divergent i.e. no focus, beam width increases with working distance. Position S4 produces the most collimated beam

(4) For S5 - S9 positions, working distance range is the range over which intensity is $\geq 90\%$ of maximum intensity. For S1-S4 positions, working distance range is the range over which intensity is $\geq 50\%$ of maximum intensity.

(5) For more details on beam width and intensities, see graphs.

Spectral Distribution

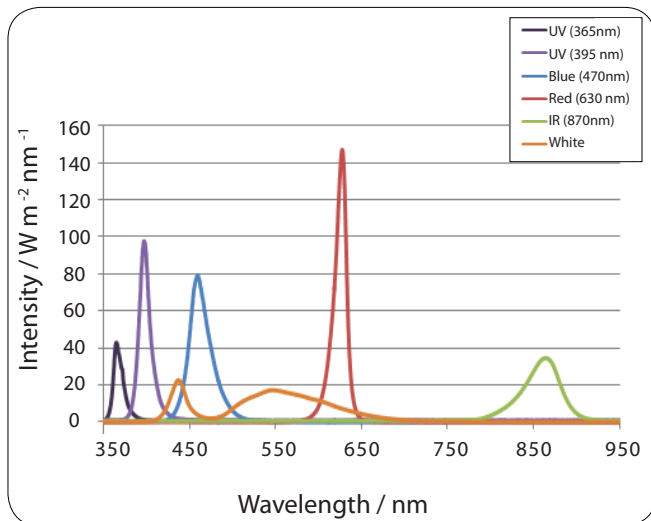

Line Width Versus Working Distance - Red

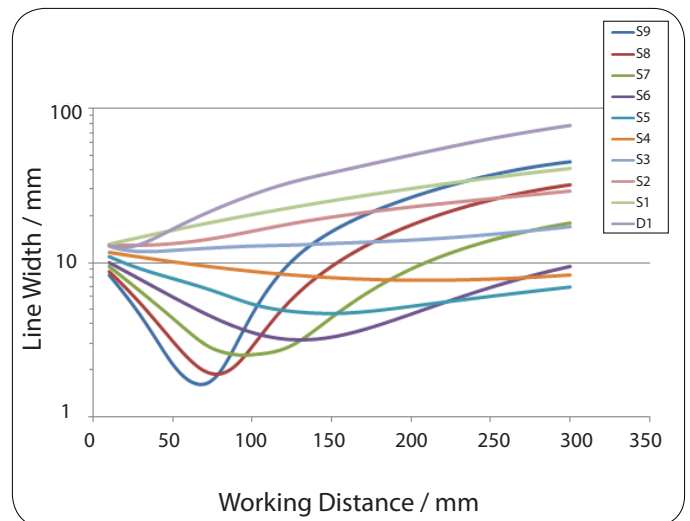

Note: Values presented for the active cooling option in the maximum irradiance and illumination table correlate to the integrals of the spectra presented here.

RED COBRA Flex

Intensity Versus WD (100 mm Unit) - Red

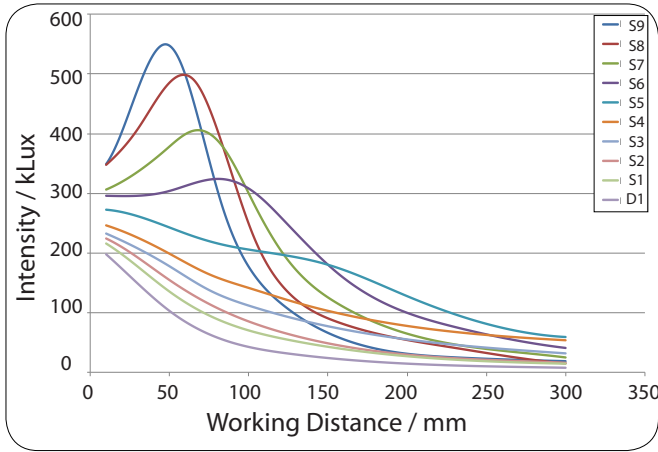

Intensity Versus WD (300 mm Unit) - Red

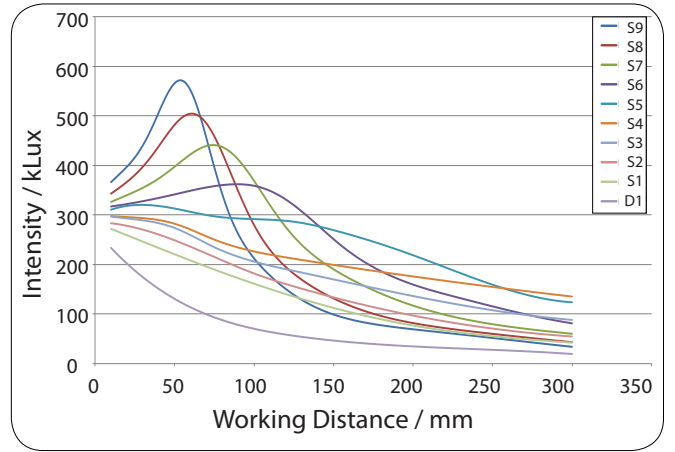

Note: The behavior of Intensity with Working Distance will be similar for units with 3 or more modules

Uniformity: 300mm Unit, S5, WD=100mm - Red

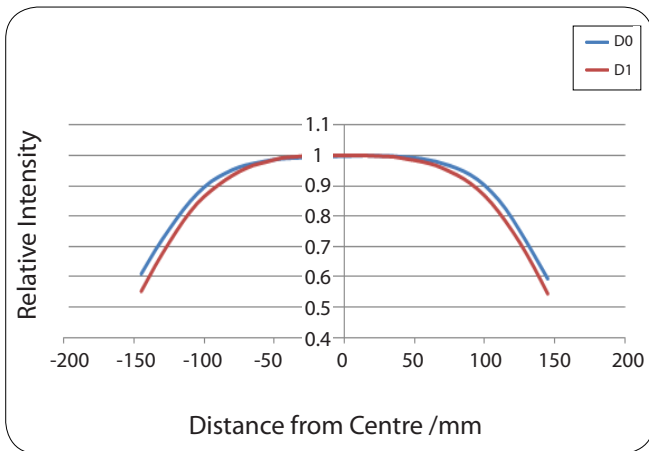

RED COBRA Flex D0	300mm Unit
Length with > 95% Intensity	165 mm
Length with > 90% Intensity	200 mm

RED COBRA Flex D1	300mm Unit
Length with > 95% Intensity	150 mm
Length with > 90% Intensity	180 mm

Note: Uniformity will vary with lens position and working distance.

Focus & Illumination Field - White COBRA Flex

Lens Position ³	Working Distance (WD) for Range Illuminance ⁽⁴⁾ (mm)		Working Distance at Peak Intensity (mm)		Line Width (FWHM) at WD (mm)		Focal Distance (mm)	Line Width at Focal Distance (mm) ⁵
	100mm	300mm	100mm	300mm	100mm	300mm		
S1	10-53	10-105	divergent	divergent	14.0-15.6	14.0-19.4	divergent	divergent
S2	10-61	10-112	divergent	divergent	12.8-13.8	12.8-16.5	divergent	divergent
S3	10-68	10-132	collimated	collimated	11.0-12.5	11.0-13.1	collimated	collimated
S4	10-85	10-150	10	10	8.7-11.5	8.7-11.5	88	8.7
S5	10-103	10-142	10	10	6.6-10.8	6.6-10.8	88	6.6
S6	10-108	10-130	10	10	5.4-9.9	5.4-9.9	71	5.4
S7	10-61	10-67	15	55	4.3-9.2	4.3-9.2	63	4.3
S8	10-55	10-57	42	46	3.8-8.3	8.3-3.8	56	3.8
S9	10-49	10-52	41	42	3.4-7.5	3.4-7.5	50	3.4
D1	10-46	10-51	divergent	divergent	10.1-14.7	10.1-15.6	divergent	divergent

(3) Positions S1 and S2 are divergent i.e. no focus, beam width increases with working distance. Position S3 produces the most collimated beam

(4) For S4 - S9 positions, working distance range is the range over which intensity is $\geq 90\%$ of maximum intensity. For S1-S3 positions, working distance range is the range over which intensity is $\geq 50\%$ of maximum intensity.

(5) For more details on beam width and intensities, see graphs.

Beam Width Versus Working Distance - White

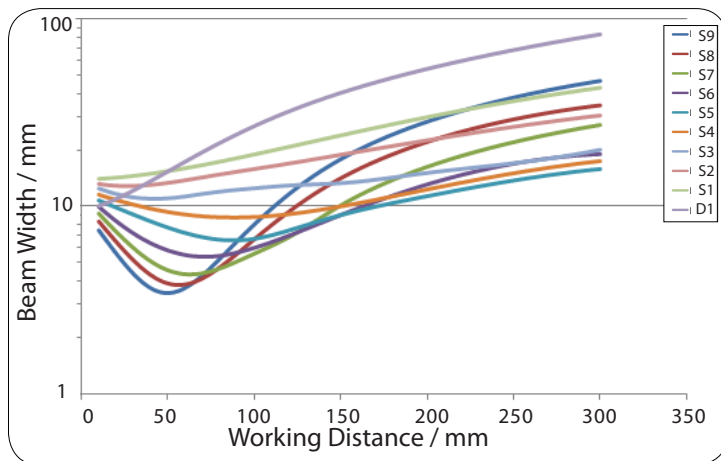

Custom Solutions

ProPhotonix specializes in providing customized solutions. Please enquire for other wavelengths, powers, optics, or mechanics.

White COBRA Flex

Intensity Versus WD (100mm Unit) - White

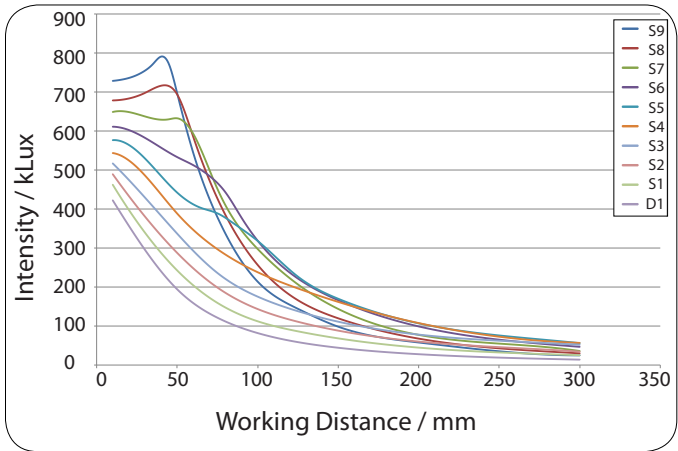

Intensity Versus WD (300mm Unit) - White

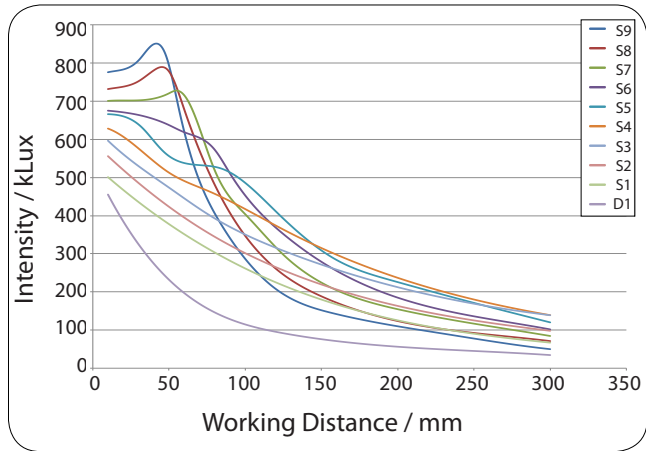

WHITE COBRA Flex D0	300mm Unit	
Length with > 95% Intensity	mm	125
Length with > 90% Intensity	mm	168

Uniformity: 300mm Unit, S5, WD=100mm

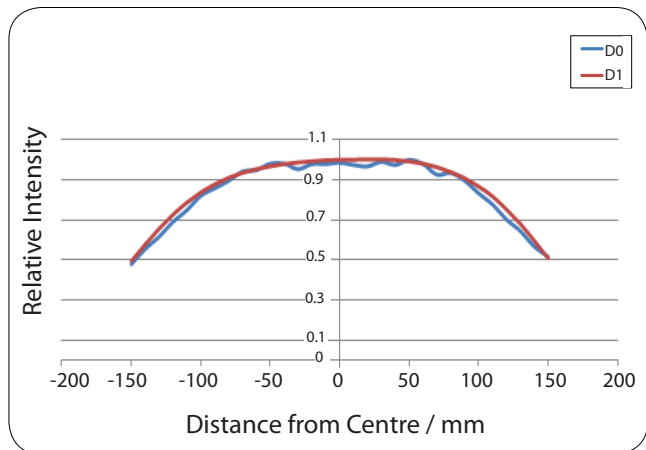

WHITE COBRA Flex D1	300mm Unit	
Length with > 95% Intensity	mm	138
Length with > 90% Intensity	mm	175

Note: Uniformity will vary with lens position and working distance.

Part Numbers

Cooling		Configuration		Standard Wavelengths (nm)		Length (mm)	Lens Type ⁽⁶⁾		Lens Position		Diffuser or Options			
C	Convection	IF	Error output & analogue control	0365	UV	0100	S	Standard	0	No Lens	D0	No Diffuser		
T	Fan	SF	IF Options + Strobe Capability	0395	UV	↓	R	Custom Optics for Broad Illumination	1	Closest to LEDs	D1	60:10 (Backlight)		
		EF	IF Options + Ethernet Connector	0470	Blue	0900	M	Max	↓	Furthest from LEDs	D2	30:1		
		AF	All Options	0630	Red	1000			9		D3	To Be Defined		
				0870	Near-IR	1100					↓			
				0000	White								D9	
				0RGB	Red, Green & Blue						↓		F1-9	Additional Focusing Lens Option
						6000							P1-9	Parallel Light (Adaptor Option)

365-1500 nm custom wavelengths available

(6) Non-standard lenses are also available on request

To order your COBRA Flex – Select Cooling Option(X) – Select Configuration (XX) – Select Wavelength Length (XXX) – Select Length (XXXX) – Select Lens Type & Position (XX) – Select Diffuser Option (XX)

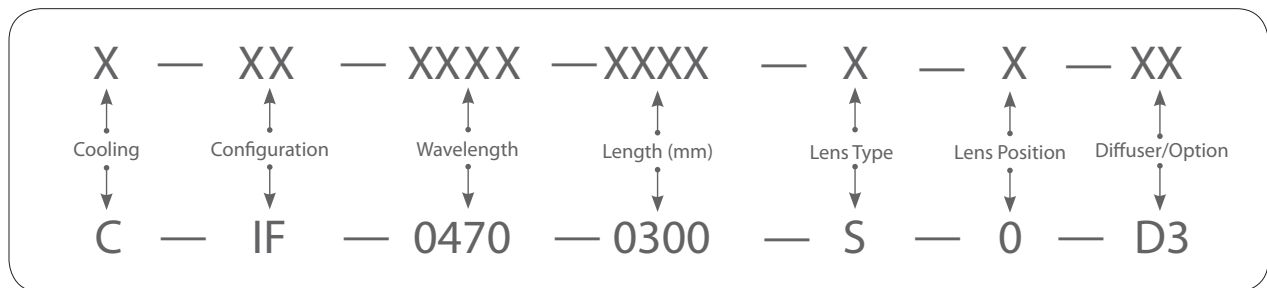

Power Requirements

Cobra Type	Power Rating Per 100mm Module	Cobra 100mm Modules Per Power Supply ⁽⁸⁾
TXF	24VDC / 48W	5 max ⁽⁷⁾
CXF	24VDC / 30W	8 max ⁽⁸⁾

(7) PSU-24V-240W-XX.or comparable 24VDC standard power supply

(8) Single power input connection

COBRA Flex comes with a 2 metre power cable as standard. This is the only cable required to use the light at full intensity. This cable can be tailored to the specific application requirements. To order the power cable use the following part number C2-CAB-P-S-XXXX where XXXX is the length of the cable in cm.

Dimensional Diagram

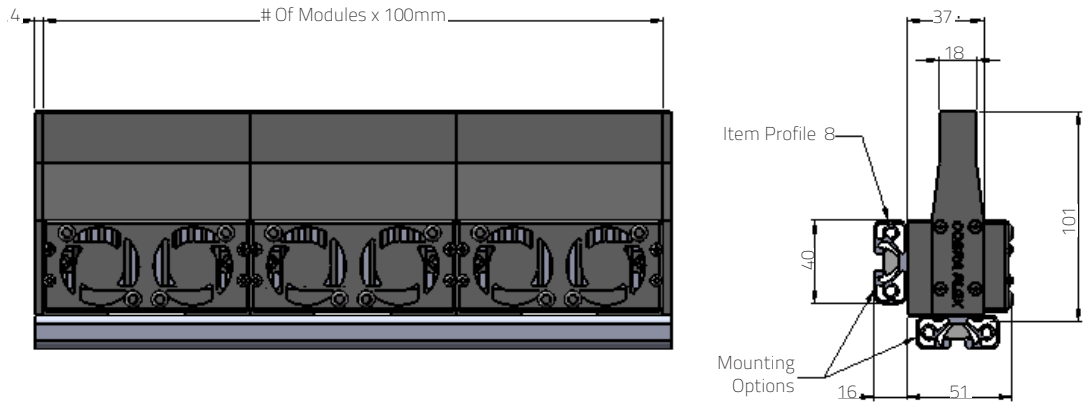

For continuous operation, Ribbon Cable can be up to 2m. If strobing is required, Ribbon cable length will be determined by strobe nature.

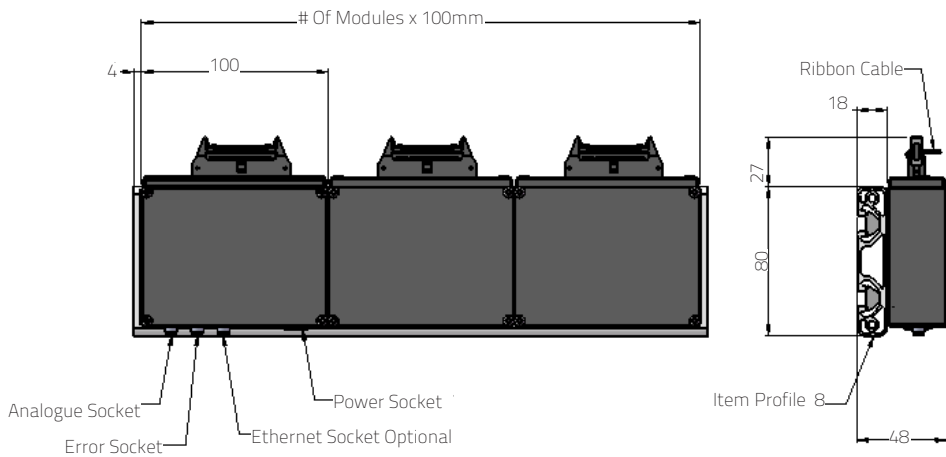

Electronics Module Mounting Option 1

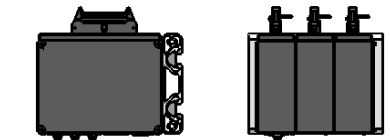

Electronics Module Mounting Option 2

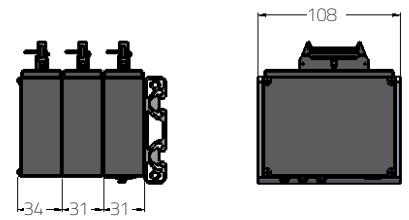

Electronics Module Mounting Option 3

For all COBRA Flex longer than 100mm, standard Item brand aluminium extrusion Profile 8 is used for rigidly aligning and connecting the 100mm COBRA Flex modules together. The extrusion is also used for mounting the light in the machine.

(Note: the overall length of the COBRA is 8mm longer than its illuminated width)



Note: Other extrusion profile forms and dimensions available on request. Custom back plates also available on request. 100mm units do not require a mounting extrusion.

260112

Corporate

32 Hampshire Road
Salem, NH 03079
sales@prophotonix.com
Tel: +1 603-893-8778
Fax: +1 603-898-8851

LED Solutions

3020 Euro Business Park,
Little Island, Cork, Ireland
sales@prophotonix.com
Tel: +353-21-5001313
Fax: +353-21-4297749

Laser Solutions

Sparrow Lane, Hatfield Broad Oak
Hertfordshire, CM22 7BA, UK
sales@prophotonix.com
Tel: +44-1279-717170
Fax: +44-1279-717171

ProPhotonix and the ProPhotonix logo are trademarks of ProPhotonix, Inc. All other brand and product names are trademarks or registered trademarks of their respective holders. Copyright © 2012 ProPhotonix, Inc. Printed in the USA. All rights reserved.



Visit us on the Web: www.prophotonix.com